

TURBO SSB 125



THE PERFECT LOW SPEED, HIGH VOLUME SLOTTED SPRAY BALL

- **Slow Constant Rotation** - **Improved Cleaning Action**
- **No Ball Bearings** - **Lower Maintenance, Longer Life**
- **High Efficiency Fan Jets** - **Reduced Cleaning Time**

VERSATILE & UNIQUE

The Breconcherry Turbo SSB 125 takes the popular slotted spray ball format into its next evolutionary phase by removing the ball bearings and slowing the rotation speed down. A unique pressure regulation system in the drive chamber helps to keep the rotation speed consistent under differing pressure. The unit functions with a hydraulic and PTFE bearing system giving the unit an increased lifetime, reducing wear and potentially prohibiting any contamination issues associated with ball bearing degradation.

APPLICATIONS

Ideally suited to high flow, variable pressure applications where a slow constant rotation speed is required to give longer chemical dwell times for improved cleaning efficiency. The tried and tested design makes the units truly versatile across any industry sector. The units are suitable for cleaning medium/large sized vessels and manufacturing equipment. Compact in design, effective in performance, they meet all the essential FDA requirements of hygiene and purity. This makes them highly suitable for the pharmaceutical, and biotech industries as well as food, beverage and other hygiene conscious industries.

OPERATION

Wash fluid is directed through the slots on the rotating ball, producing independent strong fan jets giving total coverage. Each fan jet targets a specific area of the vessel. Ideal for burst rinsing or prolonged washing with instant, strong impact performance.



Breconcherry
SellersClean

WWW.BRECONCHERRY.COM

TURBO SSB 125



Breconcherry Limited,
Lynden House
Lynden Business Park
Ledbury, Herefordshire
HR8 2DJ, UK

Tel: +44 (0)1531 632476
Fax: +44 (0)1531 633839
E-mail:
CIP@breconcherry.com



We reserve the right to change specification without notice. Whilst we endeavour to provide accurate up to date information, all information is provided as a guide only.

MAINTENANCE & INSPECTION

The low wear design requires minimal maintenance. No Spare parts are required. Technical assistance can be obtained through the global Breconcherry distributor network. As with all mechanical devices, it is recommended that the unit be regularly inspected for correct operation.

MINIMUM MANHOLE/FLANGE SIZE

The minimum manhole/flange opening size required for unit insertion is 70mm.

TECHNICAL DATA

Materials of Construction:	Stainless Steel 316L, PTFE, C-PTFE,
Max. Operating temperature:	95° Centigrade
Max. Ambient Temperature:	140° Centigrade
Available Connections:	1.25" BSP/NPT Female / 1.5" OD Tube Pin Fix / Hygienic Isolated Threaded
Nozzles Characteristics:	360° Spray Pattern

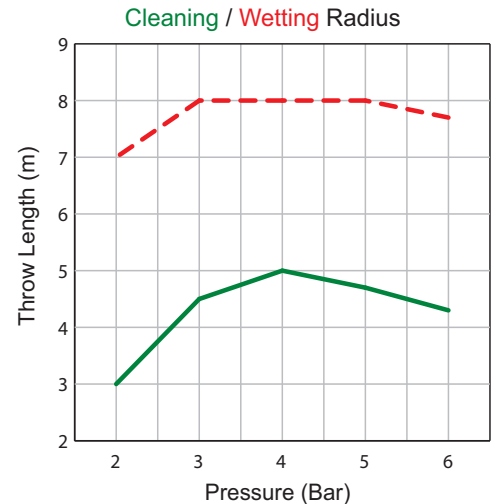
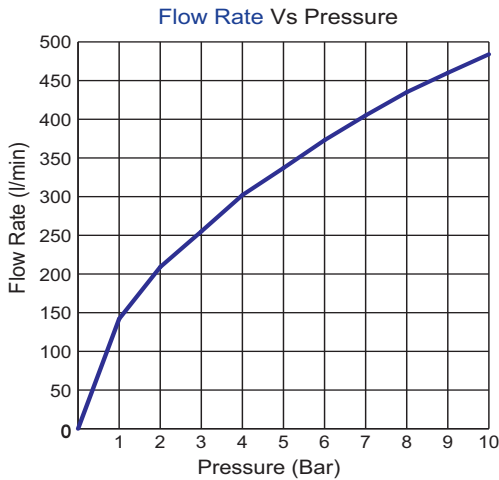

GENERAL ARRANGEMENT DRAWING

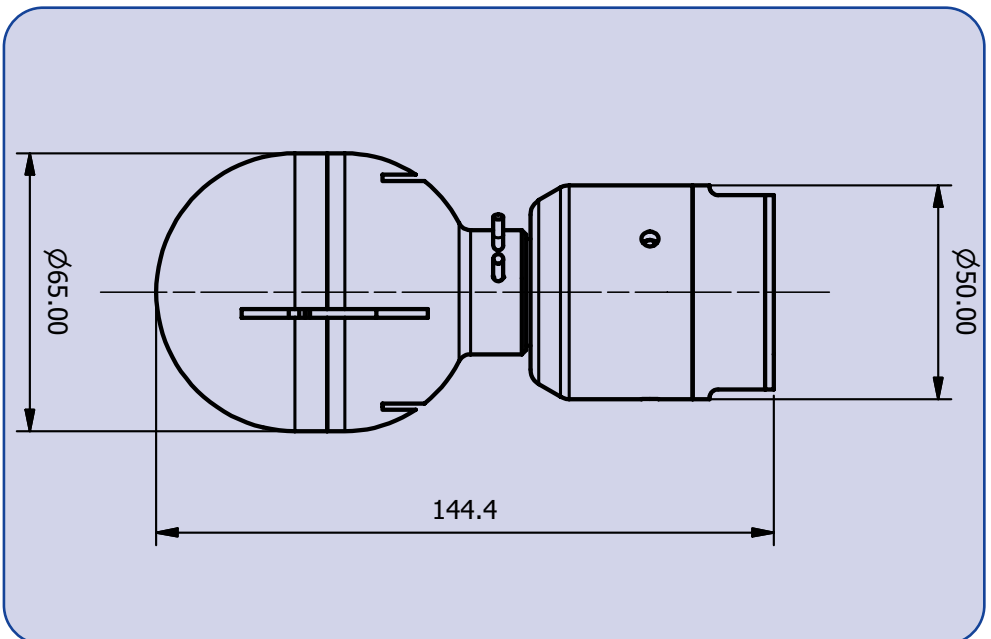

For optimal efficiency use a pre-filter or strainer to prevent particulate clogging.

